

Powered Pallet Truck

- Control tiller comes from REMA, safe and reliable. Stepless speeds is easy and safe to use for the operator.
 - Compact design from new technology. Can be used in the tightest spaces.
 - A hinged platform is also available as an option.
 - Super excellent capability drive wheels, reliability and efficiency.
 - Power unit is made in Europe technology
- Conform to EN1726 and EN1175-1

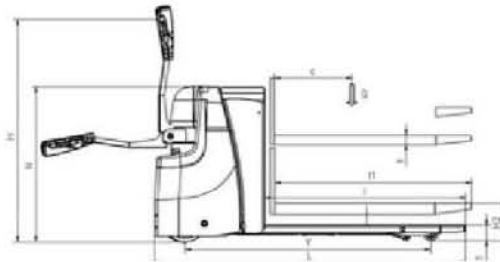
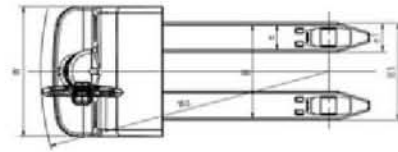

Model			HL20	HLS20
Capacity	Q	kg	2000	2000
Load center	C	mm	600	600
Turning radius	Wa	mm	1540	1540
Travel speed	laden/unladen	km/h	4.5/5	4.5/5
Lifting time	laden	s	≤4	≤4
Lowering speed	laden/unladen	mm/s	48 / 44	48 / 44
Max.gradeability kB5	laden/unladen	%	5 / 15	5 / 15
Drive motor		KW	1.2	1.2
Lift Motor,		KW/V	2.2/24	2.2/24
Battery voltage		Ah/V	220/24	220/24
Inner fork	Min.fork height	H1	mm	85
	Overall fork width	B	mm	540
	Single fork width	e	mm	160
	Fork length	l	mm	1150
Outer fork	Lift Height	H2	mm	210
	Overall fork width	B1	mm	—
	Single fork width	e1	mm	194
	Fork length	l1	mm	1150
	Lift Height	H3	mm	560
Overall fork width	W	mm	720	720
Overall height	H	mm	1310	1310
Overall dimension	LxWxH	mm	1815x720x1310	
Wheelbase	Y	mm	1370	1370
Tyre size	load end	mm	ø85x70	ø85x70
Tyre size	drive end	mm	ø230x75	ø230x75
Support roller size		mm	ø100x40	ø100x40
Weight(inc.battery)		kg	530	658

Powered Pallet Truck

- Imported control tiller safe and reliable. Stepless speeds is easy and safe to use for the operator.
- Compact design from new technology. Can be used in the tightest spaces.
- A hinged platform is also available as an option.
- Super excellent capability drive wheels, reliability and efficiency.
- Power unit is made in Europe technology Conform to EN1726 and EN1175-1

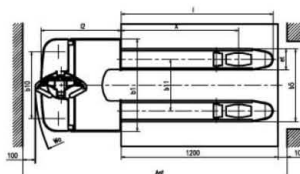
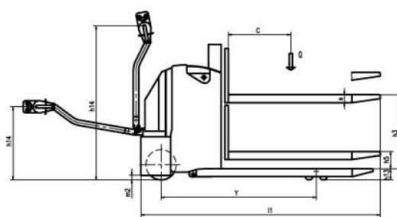

CB20



CBD20

Model			CB20	CBD20	
Capacity	Q	kg	2000	2000	
Load center	C	mm	600	600	
Turning radius	Wa	mm	1464	1661	
Travel speed	laden/unladen	km/h	4/4.8	4/4.8	
Lifting time	laden	s	≤4	≤4	
Lowering speed	laden/unladen	mm/s	48 / 44	48 / 44	
Max. gradeability	laden/unladen	%	5 / 10	5 / 10	
Drive motor		KW	1.2	1.2	
Lift Motor		KW/V	2.2/24	2.2/24	
Battery voltage		Ah/V	220/24	220/24	
Inner fork	Min.fork height	H1	mm	85	85
	Overall fork width	B	mm	550	540
	Single fork width	e	mm	160	160
	Fork length	I	mm	1150	1150
	Lift Height	H2	mm	210	210
Outer fork	Overall fork width	B1	mm	—	574
	Single fork width	e1	mm	—	194
	Fork length	I1	mm	—	1150
	Lift Height	H3	mm	—	560
Overall width	W	mm	700	720	
Overall height	H	mm	1270	1230	
Overall dimension	LxWxH	mm	1735x700x1270	1752x720x1230	
Wheelbase	Y	mm	1344	1365	
Tyre size	load end	mm	ø85x70	ø85x70	
Tyre size	drive end	mm	ø230x75	ø230x75	
Support roller size		mm	ø100x40	ø100x40	

Powered Pallet Truck HL-TE/TK series

Top Quality Range Heavy Duty Design

- ▲ Maneuver loads up ramps and dockboards effortlessly.
- ▲ Compact design combines with new technology, making this pallet truck ideal for narrow, cramped aisles. shortest head length in the market permits the best possible maneuverability.
- ▲ Smooth stepless speed control with European technology.
- ▲ Power unit with European technology.
- ▲ Powerful traction battery.
- ▲ DC driving motor with European technology.
- ▲ Drive unit with electromagnetic brake.
- ▲ **Conforms to EN1726 and EN1175-1.**

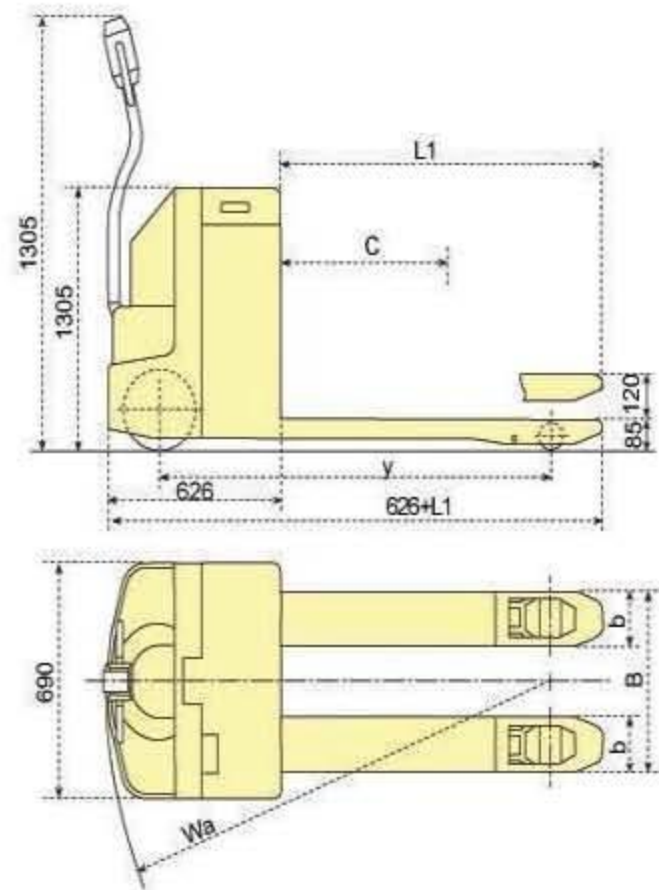

Option

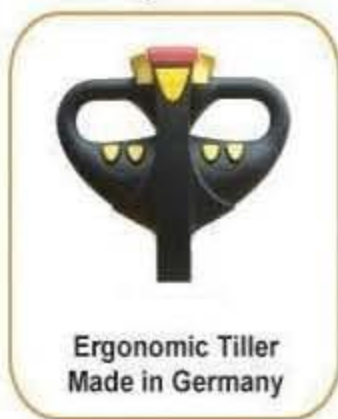

Model		HL-TE20S	HL-TE20L	HL-TK20S	HL-TK20L
Type		without platform		with platform	
Capacity	(kg)	2000		2000	
Load Center	C (mm)	600		600	
Max. Fork Height	H (mm)	205		205	
Min. Fork Height	h (mm)	85		85	
Fork Length	L1 (mm)	1150		1150	
Individual Fork Width	b (mm)	160		160	
Wheel Base	y (mm)	1406		1406	
Turning Radius	Wa (mm)	1608		1946	
Traveling Speed With/Without Load	(Km/h)	3.6/5.4		3.6/5.4	
Lifting Speed With/Without Load	(mm/s)	22/32		22/32	
Lowering Speed With/Without Load	(mm/s)	50/55		50/55	
Drive Wheel		1200W, Φ250mm		1200W, Φ250mm	
Power Unit (lifting motor)	(W/V)	800/24		800/24	
Traction Battery		24V/210Ah, 185kg		24V/210Ah, 185kg	
Battery Charger		25A/24V		25A/24V	
Overall Dimension	L×W×H (mm)	1781×690×1305		2125×690×1305	
Fork Overall Width	B (mm)	530	680	530	680
Net Weight	(kg)	324	329	338	343
Tiller		O	O	O	O

O = Option

Semi-Electric Pallet Truck HL-SE Series

- ▲ **Heavy Duty Design**
- ▲ **Brake system:**
Integral electromagnetic disk brake mounted on motor shaft.
- ▲ **Drive wheel:**
complete gear train mounted on ball and roller bearing in oil bath housing. High-torque horizontally mounted motor has coppergraphite brushes for excellent fubrication.
- ▲ **Load roller:**
Tandem Polyurethane: $\phi 78 \times 70$ mm.

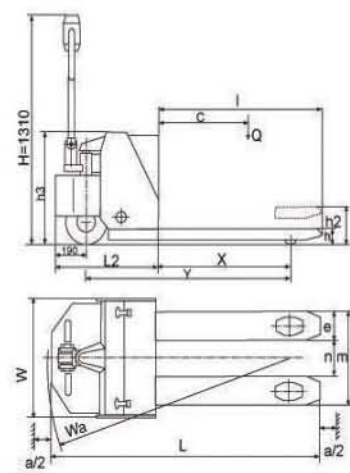

Model		HL-SE15S		HL-SE15L		HL-SE20S		HL-SE20L	
Capacity	(kg)	1500		1500		2000		2000	
Max. Fork Height	h2 (mm)	205 (or 195)		205 (or 195)		205 (or 195)		205 (or 195)	
Min. Fork Height	h (mm)	85 (or 75)		85 (or 75)		85 (or 75)		85 (or 75)	
Fork Overall Width	m (mm)	520		680		520		680	
Travelling Speed	With Load	5		5		5		5	
	Without Load	6.5		6.5		6.5		6.5	
Overall Height	H (mm)	1310		1310		1310		1310	
Overall Width	W (mm)	730		730		730		730	
Dimension	n (mm)	200		360		200		360	
	h3 (mm)	620		620		620		620	
	Wa (mm)	1350	1500	1350	1500	1350	1500	1350	1500
Overall length	L (mm)	1650	1800	1650	1800	1650	1800	1650	1800
Fork Length	l (mm)	1000	1150	1000	1150	1000	1150	1000	1150
Load Centre	C (mm)	600	650	600	650	600	650	600	650
Load distance	X (mm)	795	945	795	945	795	945	795	945
Wheel Base	Y (mm)	1240	1390	1240	1390	1240	1390	1240	1390
Net Weight (without nattery)	(kg)	215	223	225	233	238	247	248	257
Drive Wheel, Ployurethane		Motor 1200W, Wheel $\phi 250 \times 80$ mm				Motor 1200W, Wheel $\phi 250 \times 80$ mm			
Battery (service free)	(Ah/V)	80/24				80/24			
Battery Charger	(A/V)	8/24				8/24			
Traction Battery (option)	(Ah/V)	—		—		165/24		165/24	

Hand Pallet Truck HL-HP Series

One of best selling in the world.

- ▲ A built in overload valve and totally sealed hydraulic pump.
- ▲ German seal kit offers long span life of pump for 3 years warranty.
- ▲ Heavy duty and reinforced forks for greatest strength and durability.
- ▲ Entry rollers prevent physical exertion of the operator and protect load rollers and pallet.
- ▲ Maintenance free oilless bushings at key points offer you less operating force and longer span life of pallet truck.
- ▲ **Conforms to EN1757-2.**

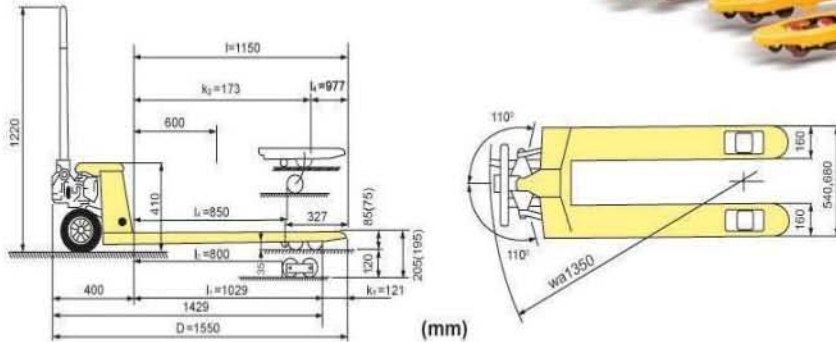

Model	HL-HP20S	HL-HP20L	HL-HP25S	HL-HP25L	HL-HP30S	HL-HP30L
Capacity (kg)	2000	2000	2500	2500	3000	3000
Max. Fork Height (mm)	205 (or 195)	205 (or 195)	205 (or 195)	205 (or 195)	205 (or 195)	205 (or 195)
Min. Fork Height (mm)	85 (or 75)	85 (or 75)	85 (or 75)	85 (or 75)	85 (or 75)	85 (or 75)
Fork Length (mm)	1150	1220	1150	1220	1150	1220
Width Overall Forks (mm)	540	680	540	680	540	680
Individual Fork Width (mm)	160	160	160	160	160	160
Load Roller Dia.xWidth (mm)	Φ80×70 (or Φ70×70) Nylon, Polyurethane					
Steering Wheel Dia.xWidth (mm)	Φ200×50 (or Φ180×50) Nylon, Polyurethane, Rubber					
Net Weight (kg)	78	82	80	84	85	89
Quick Lift (6 pump strokes)	HPQ20S	HPQ20L	HPQ25S	HPQ25L	HPQ30S	HPQ30L
With Hand Brake	HPH20S	HPH20L	HPH25S	HPH25L	HPH30S	HPH30L
With Deadman Brake	HPD20S	HPD20L	HPD25S	HPD25L	HPD30S	HPD30L
With Foot Brake	HPJ20S	HPJ20L	HPJ25S	HPJ25L	HPJ30S	HPJ30L

OPTION



Handle

Handle with Brake



Polyurethane

Nylon

Rubber

Polyurethane

Nylon

Polyurethane

Hand Pallet Truck HL-BST Series

One of the best pallet truck in the world !

- ▲ **Quick lift !**
Within 2 strokes, pallet is ready to be moved.
Highly efficient achieve maximum lift height in half the time.
Pump atomatically switches to normal operation when load exceeds 150kg.
- ▲ **Three years warranty pump !**
Unique double seals design ensures longer life than standard pump.
Quick and easy-change cassette valve system with overload protection.
- ▲ **Ergonomic handle!**
Perfectly ergonomic designed handle offers a comfortable trip in all temperatures and more lifting height per stroke then normal handle.
- ▲ **New fork design !**
Ensures 25% more strength than standard fork. The truck can be used frequently in toughest conditions.
- ▲ **New adjustable push rod !**
Extremely easy to adjust push rod without turn the truck.
- ▲ **Self-lubricating bearings !**
Ensures long lift and repairable of the truck.
- ▲ **Additional entry and exit rollers:**
Offer easier entry and exit from pallet and protect load wheels as well.
- ▲ **Conforms to EN1757-2.**

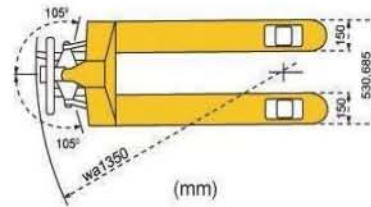
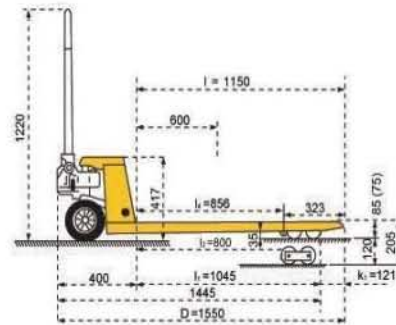

2000kg-2500kg



Ergonomic Handle



Two Years Warranty Pump!

Model		HL-BST2053	HL-BST2068	HL-BST2553	HL-BST2568	HL-BST3053	HL-BST3068
Capacity	(kg)	2000	2000	2500	2500	3000	3000
Max. Fork Height	(mm)	205 (or 195)	205 (or 195)	205 (or 195)	205 (or 195)	205 (or 195)	205 (or 195)
Min. Fork Height	(mm)	85 (or 75)	85 (or 75)	85 (or 75)	85 (or 75)	85 (or 75)	85 (or 75)
Fork Length	(mm)	1150	1220	1150	1220	1150	1220
Individual Fork Width	(mm)	150	150	150	150	160	160
Width Overall Forks	(mm)	530	685	530	685	540	680
Net Weight	(kg)	75	78	77	80	85	88

Low Profile Pallet Truck HL-HPL/HPM Series

- ▲ For super low pallet.
- ▲ **Conforms to EN1757-2.**



Model	HL-HPL20S	HL-HPL20L	HL-HPM10S	HL-HPM10L
Type	Low Profile		Super Low	
Capacity (kg)	2000	2000	1000	1000
Max. Fork Height (mm)	170	170	95	95
Min. Fork Height (mm)	55	55	36	36
Fork Length (mm)	1150	1220	1150	1200
Fork Overall Width (mm)	540	680	540	680
Net Weight (kg)	75	79	70	74

Rollers: Polyurethane
Wheels: Nylon, Polyurethane, Rubber

Galvanized Pallet Trucks HL-HPG Series

- ▲ Latest galvanizing technology offers longest span life and prevent corrosion.
- ▲ For use in corrosive environment, cold room or clean room applications.
- ▲ Chrome plated piston and valve.
- ▲ Galvanized structure including fork frame, wheel frame, push rod, handle.
- ▲ Galvanized pump with leak resistant and airless design.
- ▲ 75mm (3") lowered fork height available.
- ▲ **Conforms to EN1757-2.**



Model	HL-HPG20S	HL-HPG20L	HL-HPG25S	HL-HPG25L
Capacity (kg)	2000	2000	2500	2500
Max. Fork Height (mm)	205	205	205	205
Min. Fork Height (mm)	85	85	85	85
Fork Length (mm)	1150	1200	1150	1200
Fork Overall Width (mm)	540	680	540	680
Fork Width (mm)	160	160	160	160
Net Weight (kg)	75	78	78	81

Stainless Pallet Trucks HL-PS series

- ▲ All parts are made of stainless including hydraulic pump, fork frame, handle, push rod, bearing, pin and bolt, etc.
- ▲ For use in meat and other food industry, dairy canning and all areas where corrosive acids and saline solutions are used.
- ▲ Rollers/Wheels: Nylon.
75mm (3") lowered fork height available.
- ▲ **Conforms to EN1757-2.**



Model		HL-PS20S	HL-PS20L
Capacity	(kg)	2000	2000
Min.Fork Height	(mm)	85	85
Fork Length	(mm)	1150	1150
Width Overall Forks	(mm)	160	160
Width Overall Forks	(mm)	540	680
Net Weight	(kg)	75	78

Roll Pallet Truck HL-R series

- ▲ **Conforms to EN1757-2.**

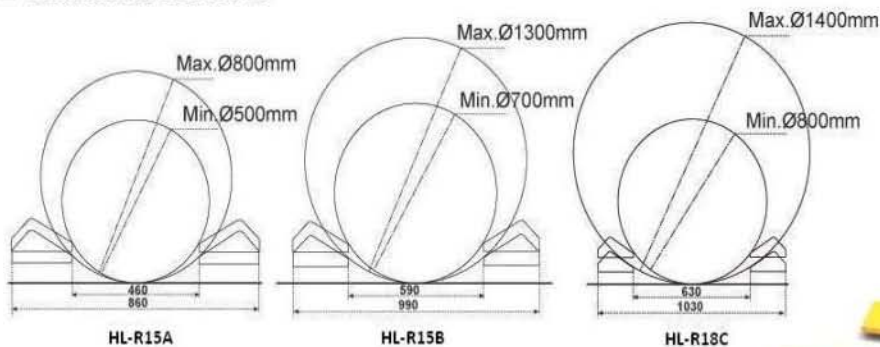

For handling roll of paper, carpet, textile or other materials.

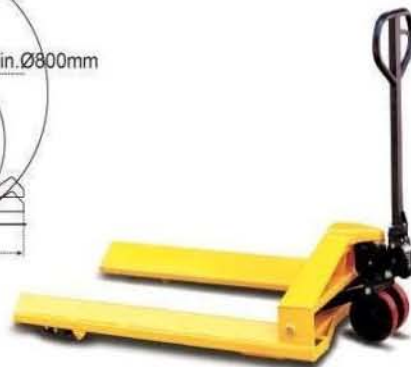

Model		HL-R15A	HL-R15B	HL-R18C
Capacity	(kg)	1500	1500	1800
Min. Roll Diameter	(mm)	Φ500	Φ700	Φ800
Max. Roll Diameter	(mm)	Φ800	Φ1300	Φ1400
Max. Roll Length	(mm)	1500	1500	1500
Fork Overall Width	(mm)	860	990	1030
Fork Length	(mm)	1350	1350	1350
Rear Wheel	(mm)	Φ200	Φ200	Φ200
Net Weight	(kg)	130	140	155

5 tonne Pallet Truck HL-HP50S

- ▲ Heavy duty design for moving heavy load.
- ▲ Unique hydraulic pump with less effort to lift heavy load easily.
- ▲ **Conforms to CE safety standard.**

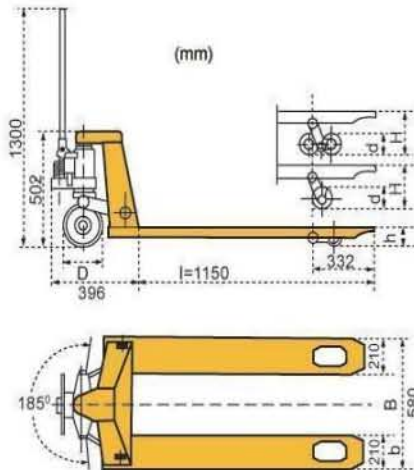

Load roller: d=Φ80×68mm, tandem steel
Steering wheel: D=Φ200×50mm, steel

Model	HL-HP50S	
Capacity	(kg)	5000
Max. Fork Height	H (mm)	200
Min. Fork Height	h (mm)	90
Fork Length	l (mm)	1150
Fork Overall Width	B (mm)	580
Fork Width	b (mm)	210
Over Size	L×W×H (mm)	1546×588×1300
Net Weight	(kg)	192

Four Way Pallet Truck HL-HPF Series

- ▲ Unique 4-directional movement capacity provides the flexibility to maneuver wide loads through standard aisles.
- ▲ An additional set of wheels allows pallet truck to be moved sideways in addition to be the conventional forward and back directions.
- ▲ Move heavy loads, quickly and effortlessly, with convenient hydraulic power and industrial quality features.
- ▲ Trucks are constructed of 4mm thick steel with reinforced fork bracing.
- ▲ Include sealed ball bearings on wheels that are permanently lubed and polyurethane coated.
- ▲ Handle has a cushion grip with a 3-position lever.



Capacity: 2000kg at fork height from 85 to 175mm.
1200kg at fork height from 185 to 205mm.

Model		HL-HPF12S	HL-HPF12L
Capacity	(kg)	2000/1200	2000/1200
Max. Fork Height	(mm)	205	205
Min. Fork Height	(mm)	85	85
Fork Length	(mm)	1150	1150
Width Overall Forks	(mm)	540	680
Rear Wheel	(mm)	Φ200	Φ200
Net Weight	(kg)	75	78